

Spare Parts List
Ersatzteilliste
Liste de pièces détachées
Lista de piezas de repuesto

2013-07

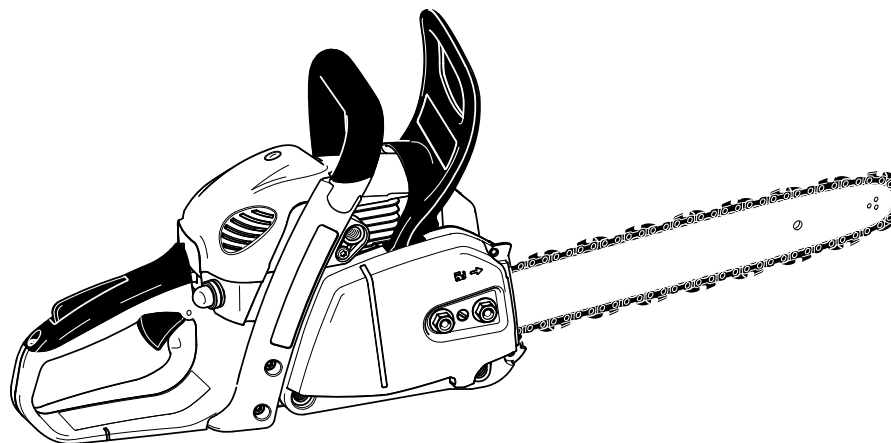

PS-32 C
PS-32 C TLC
PS-32
PS-32 TLC

DOLMAR



A member of the *Makita* Group

995700004 (D, GB, F, E)

PS-32 C, PS-32 C TLC,
PS-32, PS-32 TLC

1

Kraftstofftank, Bügelgriff
Fuel tank, tubular grip
Réserv. carburant, poignée tubulaire
Depósito de combustible, mango tubular

DOLMAR



A member of the **Trakita** Group

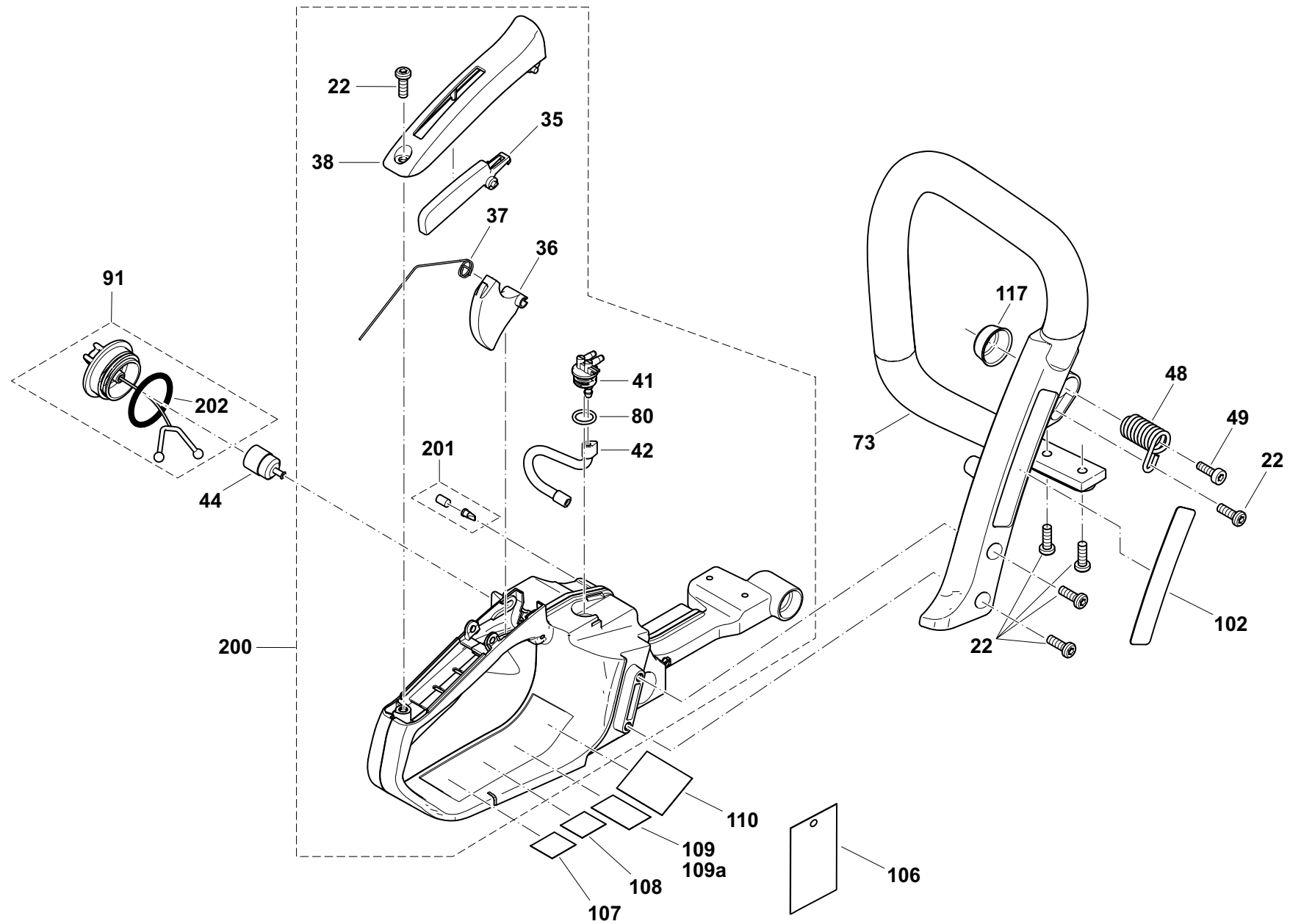

PS-32 C, PS-32 C TLC,
PS-32, PS-32 TLC

1

Kraftstofftank, Bügelgriff
Fuel tank, tubular grip
Réserv. carburant, poignée tubulaire
Depósito de combustible, mango tubular

DOLMAR
A member of the **Takita** Group

Seite / Page	Pos.	PS-32 C	PS-32 C TLC	PS-32	PS-32 TLC	Teil-Nr. Part No. No. de pièce No. de pieza	Hinweise Notes Renseign. Nota	Bezeichnung	Spezifikation Specification	Description	Désignation	Denominación
1	22	19	19	19	19	913 455 164		INNENSTERN SCHRAUBE	5,5X16	SCREW	VIS	TORNILLO
1	35	1	1	1	1	165 117 030		GASHEBELSPERRE		CATCH LEVER	LEVIER DE VERROUILLAGE	PALANCA TRINCADA
1	36	1	1	1	1	165 117 020		GASHEBEL		THROTTLE LEVER	ACCÉLÉRATEUR	PALANCA DEL ACELERADOR
1	37	1	1	1	1	195 117 010		GASHEBELFEDER		SPRING	RESSORT	MUELLE
1	38	1	1	1	1	165 117 050		GRIFFOBERSCHALE		GRIP SHELL	COQUILLE DE POIGNÉE SUPÉR.	CUBIERTA SUPER. EMPUÑADURA
1	41	1	1	1	1	165 114 060		KRAFTSTOFFNIPPEL		FUEL NIPPLE	RACCORD FILETÉ	RACOR
1	42	1	1	1	1	195 114 070		KRAFTSTOFFLEITUNG		FUEL PIPE	CONDUITE CARB.	TUBO COMB.
1	44	1	1	1	1	320 163 447		BENZINFILTER		FUEL FILTER	FILTRE D'ESSENCE	FILTRO DE GASOLINA
1	48	4	4	4	4	195 114 150		DÄMPFUNGSFEDER	12	SPRING	RESSORT	RESORTE
1	49	5	5	5	5	908 005 165		SCHRAUBE INNEN6RD ZK	M5x16	H.L. SOCKET HEAD BOLT	VIS	TORNILLO
1	73	1	1	1	1	165 310 010		BÜGELGRIFF		TUBULAR HANDLE	POIGNEE TUBULAIRE	MANGO TUBULAR
1	80	1	1	1	1	963 211 020		O-RING	11,5x2	O RING	ANNEAU TORIQUE	ANILLO OBTURADOR
1	91	2	2	2	2	181 114 202		TANKDECKEL KPL.		TANK CAP CPL.	BOUCHON RESERVOIR CPL.	TORNILLO DE CIERRE CPL.
1	102	1	1	1	1	165 115 130		SCHILD BÜGELGRIFF	DOLMAR LOGO	LABEL	PLAQUE	CALCOMANIA
1	106	1	1	1	1			ANHÄNGESCHILD	AIR INDEX, USA	TAG	PLAQUE	PLACA
1	107	1	1	1	1			AUFKLEBER	BR	LABEL	PLAQUE	CALCOMANIA
1	107	1	1	1	1			SICHERHEITSAUFKLEBER	USA	CAUTION LABEL	PLAQUE	CALCOMANIA
1	108	1	1	1	1			SCHALLPEGELAUFKLEBER	EU, USA	LABEL, SOUND LEVEL	PLAQUE, SONORE	CALCOMANIA, NIVEL DE SONORA
1	109	1	1	1	1			ABGASAUFKLEBER	USA	LABEL, EXHAUST EMISSION	PLAQUE, GAZ D'ÉCHAPPEMENT	CALCOMANIA, GAS DE ESCAPE
1	109	1	1	1	1			ABGASAUFKLEBER	EU	LABEL, EXHAUST EMISSION	PLAQUE, GAZ D'ÉCHAPPEMENT	CALCOMANIA, GAS DE ESCAPE
1	109a	1	1	1	1			AUFKLEBER TANK	USA - EVAPORATION DOLMAR	LABEL, TANK	PLAQUE, RÉSERVOIR	CALCOMANIA, DEPÓSITO
1	110	1	1	1	1			TYPENSCHILD		NAME PLATE	PLAQUE SIGNATIQUE	PLACA DE CARACTERÍSTICAS
1	117	1	1	1	1	195 114 160		FEDERTOPF		SPRING GUIDING HEAD	TÊTE DE GUIDE DE RESSORT	COPA DE GUÍA DEL MUELLE
1	200	1	1	1	1	165 114 140		KRAFTSTOFFTANK KPL. ROT	RED	TANK COMPLETE	RÉSERVOIR COMPLET	DEPÓSITO CPL.
1	200	1	1	1	1	165 114 160		KRAFTSTOFFTANK KPL. ROT	RED, USA (EPA), INCL.109a	TANK COMPLETE	RÉSERVOIR COMPLET	DEPÓSITO CPL.
1	201	1	1	1	1	170 175 010		SATZ BELÜFTUNGSVENTIL		AIR VALVE CPL.	SOUPAPE D'AERATION CPL.	VÁLVULA VENTILACION CPL.
1	202	2	2	2	2	963 229 036		O-RING	29,3X3,6	PACKING RING	BAGUE-JOINT	ANILLO DE GUARNICION

PS-32 C, PS-32 C TLC,
PS-32, PS-32 TLC

2

Abdeckhaube, Luftfilter, Schalldämpfer
Hood, air filter, muffler
Capot protecteur, filtre à air, pot d'échappement
Cubierta protectora, filtro de aire, silencioso

DOLMAR



A member of the *Trakita* Group

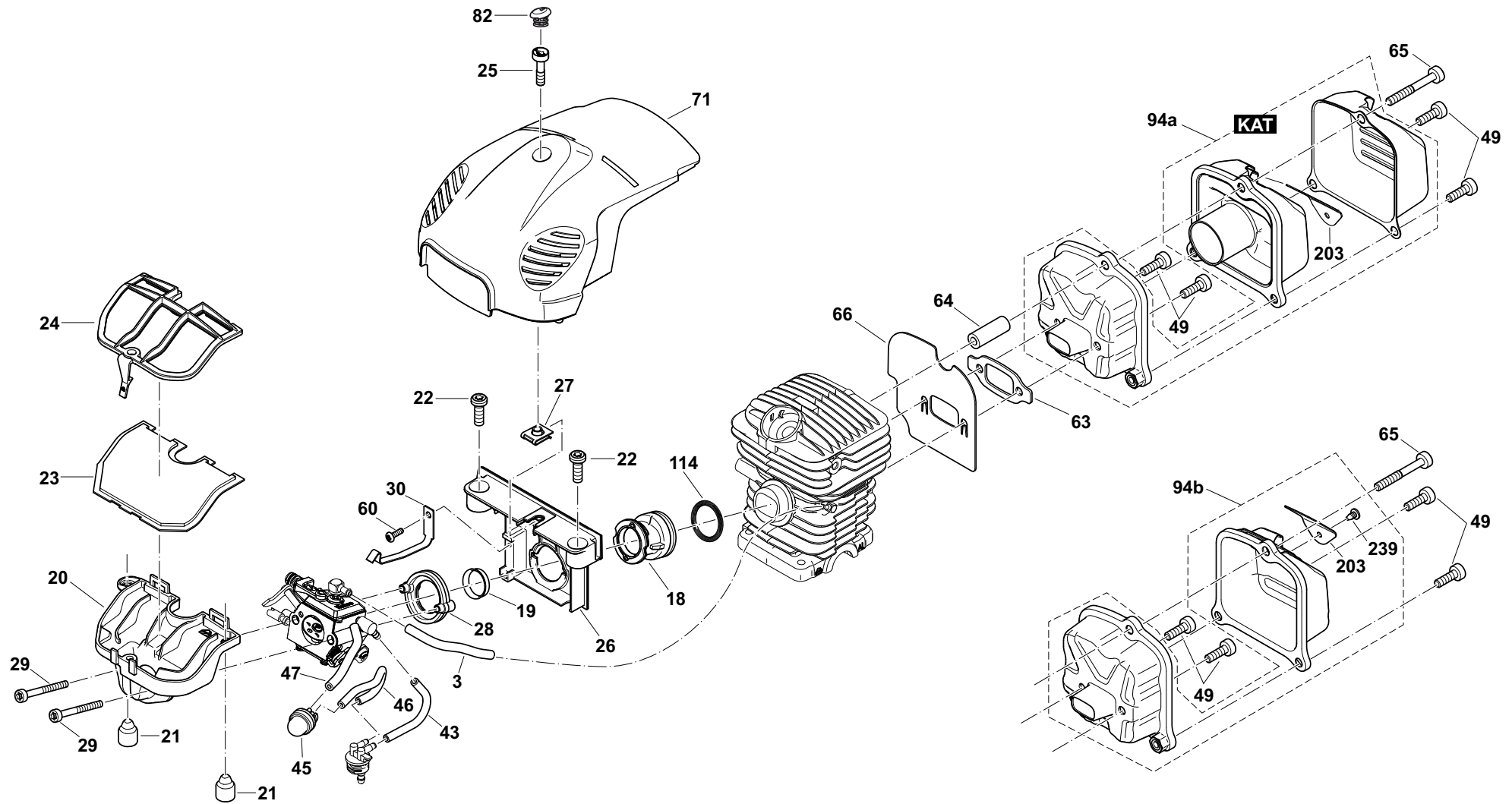

PS-32 C, PS-32 C TLC,
PS-32, PS-32 TLC

2

Abdeckhaube, Luftfilter, Schalldämpfer
Hood, air filter, muffler
Capot protecteur, filtre à air, pot d'échappement
Cubierta protectora, filtro de aire, silencioso

DOLMAR
A member of the **Takita** Group

Seite / Page	Pos.	PS-32 C	PS-32 C TLC	PS-32	PS-32 TLC	Teil-Nr. Part No. No. de pièce No. de pieza	Hinweise Notes Renseign. Nota	Bezeichnung	Spezifikation Specification	Description	Désignation	Denominación
2	3	m	m	m	m	965 452 090		VITONSCHLAUCH	2,5/5,5mm x1m 72 mm	TUBE	GAINE	TUBO
2	18	1	1	1	1	165 131 040		ANSAUGSCHLAUCH		INTAKE HOSE	TUYAU D'ASPIRATION	TUBO DE ASPIRACIÓN
2	19	1	1	1	1	181 131 021		EINSATZ FÜR ANSAUGSCHLAUCH		INSERT	PIÈCE D'INSERTION	PIEZA DE CIERRE
2	20	1	1	1	1	165 171 010		ANSAUGKRÜMMER		INTAKE MANIFOLD	MANCHON DE JONCTION	MANGUITO DE CON.
2	21	2	2	2	2	181 118 070		DÄMPFUNGSSTOPFEN		DAMPING PLUG	TAMPON	TAPÓN DE AMORTIGUACIÓN
2	22	17	17	17	17	913 455 164		INNENSTERN SCHRAUBE	5,5X16	SCREW	VIS	TORNILLO
2	23	1	1	1	1	165 173 010		LUFTFILTER		AIR FILTER	FILTRE A AIR	FILTRE A AIR
2	24	1	1	1	1	165 173 020		LUFTFILTERDECKEL		AIR FILTER COVER	COUVERCLE DE FILTRE	TAPE DE FILTRO
2	25	1	1	1	1	165 888 050		SCHRAUBE INNEN6RD	M5X20	H.L. SOCKET HEAD BOLT	VIS	TORNILLO
2	26	1	1	1	1	165 131 050		ZWISCHENFLANSCH		INTERMEDIATE FLANGE	BRIDE INTERMEDIAIRE	BRIDA INTERMEDIA
2	27	1	1	1	1	165 171 020		SCHNAPPMUTTER	M5	SNAP NUT	ECROU	TUERCA
2	28	1	1	1	1	165 131 060		FLANSCHRING		FLANGE RING	BRIDE DE ANNEAU	BRIDA DE COLLAR
2	29	2	2	2	2	165 888 020		SCHRAUBE	M4x40	H.L. SOCKET HEAD BOLT	VIS	TOMILLO
2	30	1	1	1	1	165 155 010		KONTAKTFEDER		CONTACT SPRING	RESSORT DE CONTACT	MUELLE DE CONTACTO
2	43	1	1	1	1	965 452 660		VITONSCHLAUCH	5,6/3mmx1m EPA code, red L=70 mm	TUBE	GAINE	TUBO
2	45	1	1	1	1	010 155 010		KRAFTSTOFFPUMPE	PRIMER	PRIMER	POMPE À CARBURANT	BOMBA DE COMBUSTIBLE
2	46	1	1	1	1	965 452 090		VITONSCHLAUCH	2,5/5,5mm x1m L=112 mm	TUBE	GAINE	TUBO
2	47	1	1	1	1	965 452 090		VITONSCHLAUCH	2,5/5,5mm x1m L=55 mm	TUBE	GAINE	TUBO
2	49	5	5	5	5	908 005 165		SCHRAUBE INNEN6RD ZK	M5x16	H.L. SOCKET HEAD BOLT	VIS	TORNILLO
2	60	4	4	4	4	165 888 120		SCHRAUBE	3X10 KS K	TAPPING SCREW	VIS	TORNILLO
2	63	1	1	1	1	195 174 060		DICHTUNG FÜR SCHALLDÄMPFER	KAT	GASKET	JOINT	JUNTA
2	64	1	1	1	1	038 174 030		ZWISCHENSTÜCK	L=26,8mm	CONNECTING LINK	INTERMEDIAIRE	PIEZA INTERMEDIARIA
2	65	1	1	1	1	908 305 405		SCHRAUBE INNEN6RD ZK	M5x40	H.L. SOCKET HEAD BOLT	VIS	TORNILLO
2	66	1	1	1	1	165 174 180		KÜHLBLECH		COOLING PLATE	TÔLE DE REFROIDISSEMENT	CHAPA DE REFRIGERACION
2	71	1	1	1	1	165 118 010		ABDECKHAUBE		HOOD	CAPOT PROTECTEUR	TAPA PROTECTORA
2	82	1	1	1	1	165 118 030		KAPPE		HOOD CAP	BOUCHON	TAPÓN
2	94a	1	1			165 174 100		SCHALLDÄMPFER KPL.	KAT	MUFFLER CPL.	POT D'ECHAPPEMENT CPL.	SILENCIADOR CPL.
2	94b			1	1	165 174 200		SCHALLDÄMPFER KPL. OHNE KAT		MUFFLER CPL. WITHOUT CATALYST	POT D'ÉCHAPPEMENT S.CATALYSEUR	SILENCIADOR SIN CATALIZADOR
2	114	1	1	1	1	181 131 070		RINGFEDER		ANNULAR SPRING	RESSORT ANNULAIRE	MUELLE DE ANILLO
2	203	1	1	1	1	165 174 170		FUNKENSCHUTZSIEB		SPARK ARRESTER SCREEN	TAMIS	TAMIZ
2	239			1	1	165 174 270		SCHRAUBE	4x8	SCREW	VIS	TORNILLO

PS-32 C, PS-32 C TLC,
PS-32, PS-32 TLC

3

Zylinder, Kurbelwelle
Cylinder, crankshaft
Cylindre, vilebrequin
Cilindro, cigüeñal

DOLMAR
A member of the *Trakita* Group

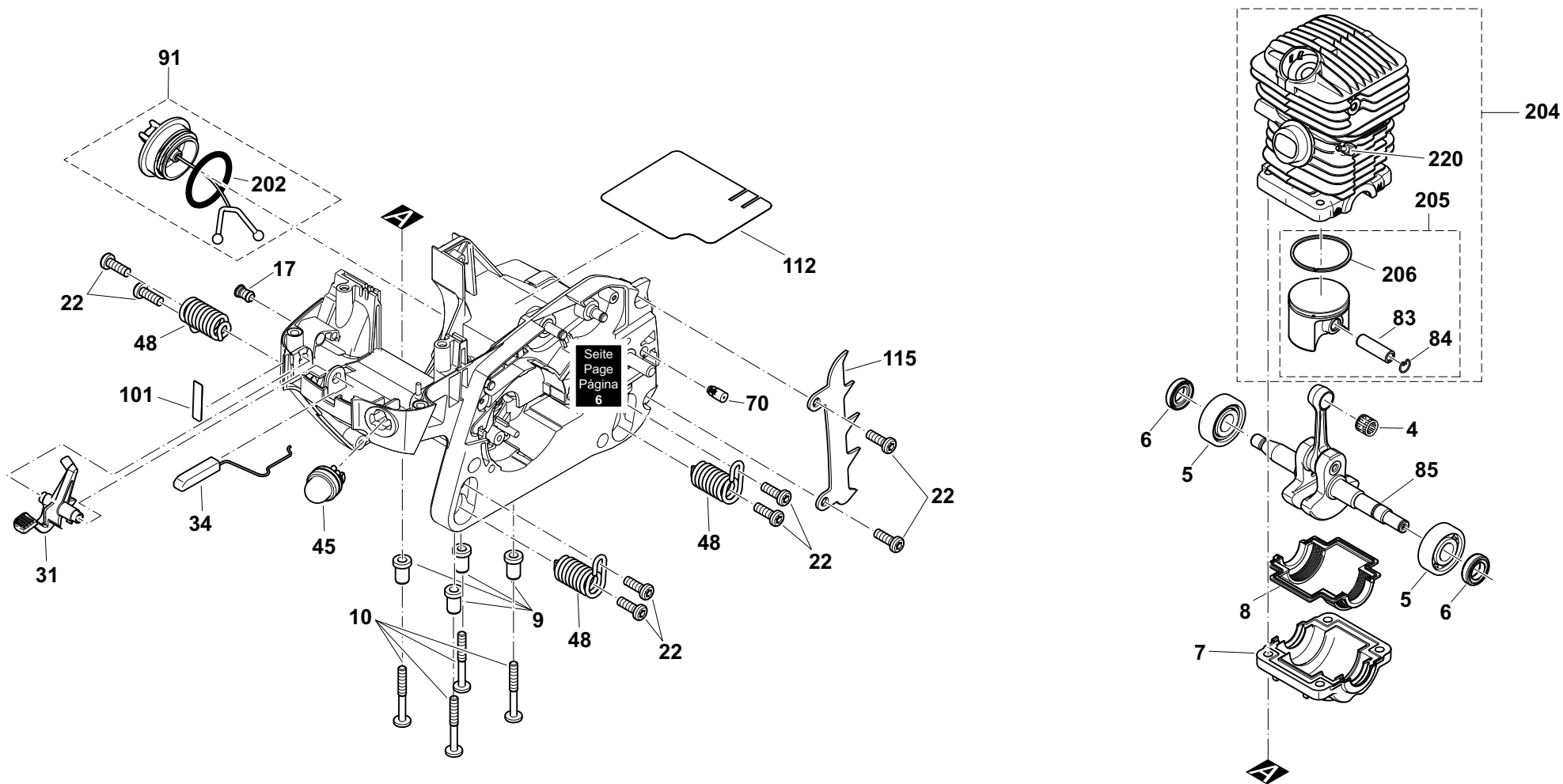

PS-32 C, PS-32 C TLC,
PS-32, PS-32 TLC

3

Zylinder, Kurbelwelle
Cylinder, crankshaft
Cylindre, vilebrequin
Cilíndro, cigüeñal

DOLMAR
A member of the **Takita** Group

Seite / Page	Pos.	PS-32 C	PS-32 C TLC	PS-32	PS-32 TLC	Teil-Nr. Part No. No. de pièce No. de pieza	Hinweise Notes Renseign. Nota	Bezeichnung	Spezifikation Specification	Description	Désignation	Denominación
3	4	1	1	1	1	962 210 082		NADELKÄFIG	K8X11X10 FKV11	NEEDLE CAGE	CARTER-COTE	CARTER CIGUENAL
3	5	2	2	2	2	165 111 010		KUGELLAGER	6201	BALL BEARING	ROULEMENT À BILLES	RODAMIENTO DE BOLAS
3	6	2	2	2	2	962 900 057		RADIALDICHTUNG		RADIAL RING	JOINT RADIAL	JUNTA RADIAL
3	7	1	1	1	1	165 111 040		UNTERSCHALE		CRANKCASE UNDERSIDE	COQUE EN BAS	BAJA LA CÁSCARA
3	8	1	1	1	1	165 111 051		KURBELGEHÄUSEDICHTUNG		CRANK CASE SEALING	JOINT	JUNTA
3	9	4	4	4	4	165 110 030		BUCHSE	6	BUSH	DOUILLE	CASQUILLO
3	10	4	4	4	4	913 350 404		SCHRAUBE	5x40 E-JOT	SCREW	VIS	TORNILLO
3	17	1	1	1	1	165 151 300		STOPFEN		PLUG	BOUCHON	TAPÓN
3	22	17	17	17	17	913 455 164		INNENSTERN SCHRAUBE	5,5X16	SCREW	VIS	TORNILLO
3	31	1	1	1	1	165 155 020		CHOKEHEBEL		CHOKE LEVER	LEVIER DE STARTER	PALANCA ESTRANGUL.AIRE
3	34	1	1	1	1	125 117 120		GASGESTÄNGE KPL.		THROTTLE LINKAGE CPL.	TRINGLE D'ACCELERATION CPL.	VARILLA ACELERADOR CPL.
3	45	1	1	1	1	010 155 010		KRAFTSTOFFPUMPE	PRIMER	PRIMER	POMPE À CARBURANT	BOMBA DE COMBUSTIBLE
3	48	4	4	4	4	195 114 150		DÄMPFUNGSFEDER	12	SPRING	RESSORT	RESORTE
3	70	1	1	1	1	010 245 030		BELÜFTUNGSVENTIL		VENT VALVE	SOUPAPE D AERATION	VALVULA VENTILACION
3	83	1	1	1	1	165 132 130		KOLBENBOLZEN	8	PISTON PIN	AXE DE PISTON	PERNO DE PISTON
3	84	1	1	1	1	165 132 140		SPRENGRING	8	PRING RING	ANNEAU RESSORT	ANILLO ELÁSTICO
3	85	1	1	1	1	165 120 100		KURBELWELLE KPL.		CRANKSHAFT CPL.	VILBREQUIN CPL.	CIGÜEÑAL CPL
3	91	2	2	2	2	181 114 202		TANKDECKEL KPL.		TANK CAP CPL.	BOUCHON RESERVOIR CPL.	TORNILLO DE CIERRE CPL.
3	101	1	1	1	1	980 114 928		AUFKLEBER	CHOKE I-0	LABEL	PLAQUE	CALCOMANIA
3	112	1	1	1	1	165 111 080		HITZESCHUTZFOLIE		HEAT PROTECTION FOIL	FILM DE CHALEUR	FOLIO AL CALOR
3	115	1	1	1	1	195 250 010		ZACKENLEISTE		SPIKE BAR	BARRE DENTÉE	BARRA DENTADA
3	202	2	2	2	2	963 229 036		O-RING	29,3X3,6	PACKING RING	BAGUE-JOINT	ANILLO DE GUARNICION
3	204	1	1	1	1	957 131 140		ZYLINDER / KOLBEN KPL. (MIT WINKELNIPPEL)	D38MM (INC. 220)	CYLINDER / PISTON CPL. (WITH ANGULAR NIPPLE)	CYLINDRE ET PISTON CPL. (AVEC TÉTON COUDÉ)	CILINDRO CON PISTÓN CPL. (CON BOUQUILLA ANGULAR)
3	205	1	1	1	1	165 132 200		KOLBEN KPL.	D38MM	PISTON CPL.	PISTON CPL.	PISTÓN CPL.
3	206	1	1	1	1	194 132 020		KOLBENRING	Ø 38	PISTON RING	SEGMENT DE PISTON	SEGMENTO DE PISTÓN
3	220	1	1	1	1	001 151 770		WINKELNIPPEL		ANGULAR NIPPLE	TÉTON COUDÉ	BOUQUILLA ANGULAR

PS-32 C, PS-32 C TLC,
PS-32, PS-32 TLC

4

Zündelektronik, Anwerfvorrichtung
Ignition electronics, starter
Allumage électronique, dispositif de démarrage
Bobina encendido, dispositivo de arranque

DOLMAR
A member of the *Trakita* Group

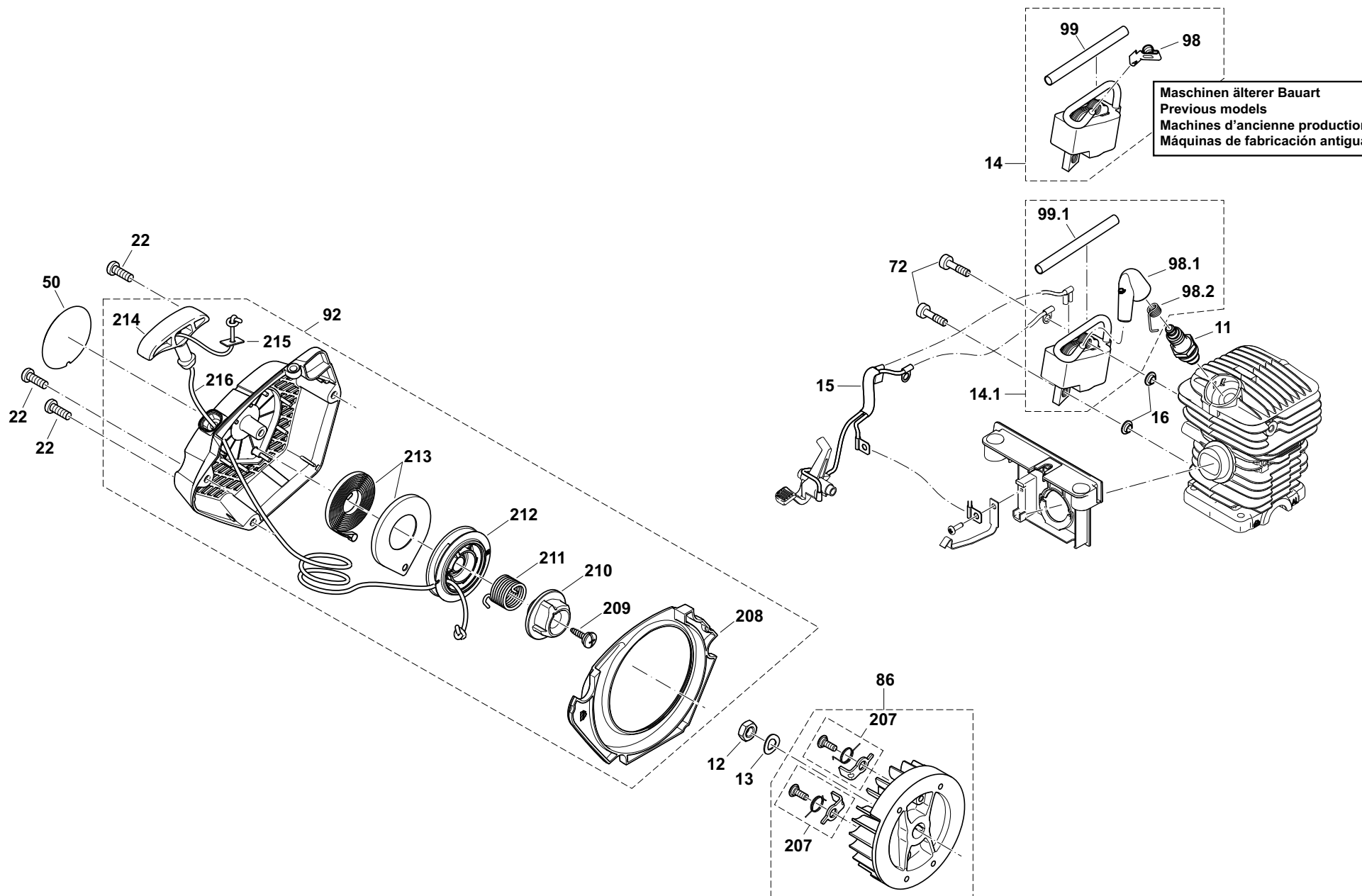

PS-32 C, PS-32 C TLC,
PS-32, PS-32 TLC

4

Zündelektronik, Anwerfvorrichtung
Ignition electronics, starter
Allumage électronique, dispositif de démarrage
Bobina encendido, dispositivo de arranque

DOLMAR
A member of the **Takita** Group

Seite / Page	Pos.	PS-32 C	PS-32 C TLC	PS-32	PS-32 TLC	Teil-Nr. Part No. No. de pièce No. de pieza	Hinweise Notes Renseign. Nota	Bezeichnung	Spezifikation Specification	Description	Désignation	Denominación
4	11	1	1	1	1	965 603 030		ZÜNDKERZE	NGK CMR6A	SPARK PLUG	BOUGIE	BUJÍA
4	12	1	1	1	1	920 308 024		6KT-MUTTER	M8x1	HEXAGONAL NUT	ECROU HEXAGONAL	TUERCA HEXAGONAL
4	13	1	1	1	1	926 208 001		FEDERSCHEIBE	B8	SPRING WASHER	RONDELLE ÉLASTIQUE	DISCO AMORTIGUADOR
4	14	1	1	1	1	165 143 100		ZÜNDSPULE KPL.		IGNITION COIL, CPL.	BOBINE D'ALLUMAGE CPL.	BOBINA DE ENCENDIDO CPL.
4	14.1	1	1	1	1	165 143 101		ZÜNDSPULE KPL.		IGNITION COIL, CPL.	BOBINE D'ALLUMAGE CPL.	BOBINA DE ENCENDIDO CPL.
4	15	1	1	1	1	165 147 020		KABELBAUM		CABLE HARNESS	FAISCEAU DE CABLES	MAZO DE CABLES
4	16	2	2	2	2	195 143 030		ISOLIERSCHEIBE	black	ISOLATING WASHER	RONDELLE	ARANDELA
4	22	17	17	17	17	913 455 164		INNENSTERN SCHRAUBE	5,5X16	SCREW	VIS	TORNILLO
4	50	1	1	1	1	165 115 010		SCHILD	PS-32	MODEL LABEL	PLAQUE	CALCOMANIA
4	72	2	2	2	2	165 888 130		SCHRAUBE INNEN6RD	M5X20 PRECOTE	H.L. SOCKET HEAD BOLT	VIS	TORNILLO
4	86	1	1	1	1	165 141 100		POLRAD KPL.		FLYWHEEL COMPLETE	ROUE POLAIRE CPL.	VOLANTE ENCENDIDO CPL.
4	92	1	1	1	1	165 160 100		STARTER KPL., ROT	RED	STARTER COMPLETE	STARTER CPL.	ARRANCADOR CPL.
4	98	1	1	1	1	965 604 190		ZÜNDKERZENSTECKER		SPARK PLUG CAP	FICHE DE BOUGIE	TAPA DE BUJÍA
4	98.1	1	1	1	1	125 143 010		ZÜNDKERZENSTECKER		SPARK PLUG CAP	FICHE DE BOUGIE	TAPA DE BUJÍA
4	98.2	1	1	1	1	125 143 020		FEDER		SPRING	RESSORT	RESORTE
4	99	m	m	m	m	970 502 110		ISOLIERSCHLAUCH	A6X0,5 95 mm	ISOLATING HOSE	TUYAU ISOLANT	MANGO AISLANTE
4	99.1	m	m	m	m	970 502 110		ISOLIERSCHLAUCH	A6X0,5 80 mm	ISOLATING HOSE	TUYAU ISOLANT	MANGO AISLANTE
4	207	1	1	1	1	165 166 100		ANWERFKLINKE KPL.		STARTER RATCHET CPL.	CLIQUET CPL.	TRINQUETE ARRANQUE CPL.
4	208	1	1	1	1	165 160 021		LUFTFÜHRUNG		AIR GUIDE PLATE	GUIDE D' AIR	CONDUCTO DE AIRE
4	209	1	1	1	1	195 160 010		SCHRAUBE		SCREW	VIS	TORNILLO
4	210	1	1	1	1	170 160 780		MITNEHMER	EASY START	STARTER WHEEL	ROUE DÉCLENCHÉUR	RUEDA DE ARRANQUE
4	211	1	1	1	1	195 160 030		FEDER		SPRING	RESSORT	MUELLE
4	212	1	1	1	1	195 160 040		SEILTROMMEL		CABLE DRUM CPL.	TAMBOUR DE CÂBLE CPL.	TAMBOUR PARA CORDÓN CPL.
4	213	1	1	1	1	195 160 110		STARTERFEDER		REWIND SPRING	RESSORT DE RAPPEL	RESORTE RETENCIÓN
4	214	1	1	1	1	195 160 070		ANWERFGRIF		STARTER GRIP	POIGNÉE DE LANCEMENT	TIRADOR DE ARRANQUE
4	215	1	1	1	1	195 160 080		SCHWEIBE		WASHER	RONDELLE	ARANDELA
4	216	m	m	m	m	985 000 150		ANWERFSEIL	ø 3 x 100 m	STARTER ROPE	CÂBLE	CORDÓN DE ARRANQUE
4	216	1	1	1	1	021 164 010		ANWERFSEIL	ø 3 x 900 mm	STARTER ROPE	CÂBLE	CORDÓN DE ARRANQUE

PS-32 C, PS-32 C TLC,
PS-32, PS-32 TLC

5

Ölpumpe, Kupplung, Kettenbremse
Oil pump, clutch, chain brake
Pompe à huile, embrayage, frein de chaîne
Bomba de aceite, engrague, freno de cadena

DOLMAR



A member of the **Takita** Group

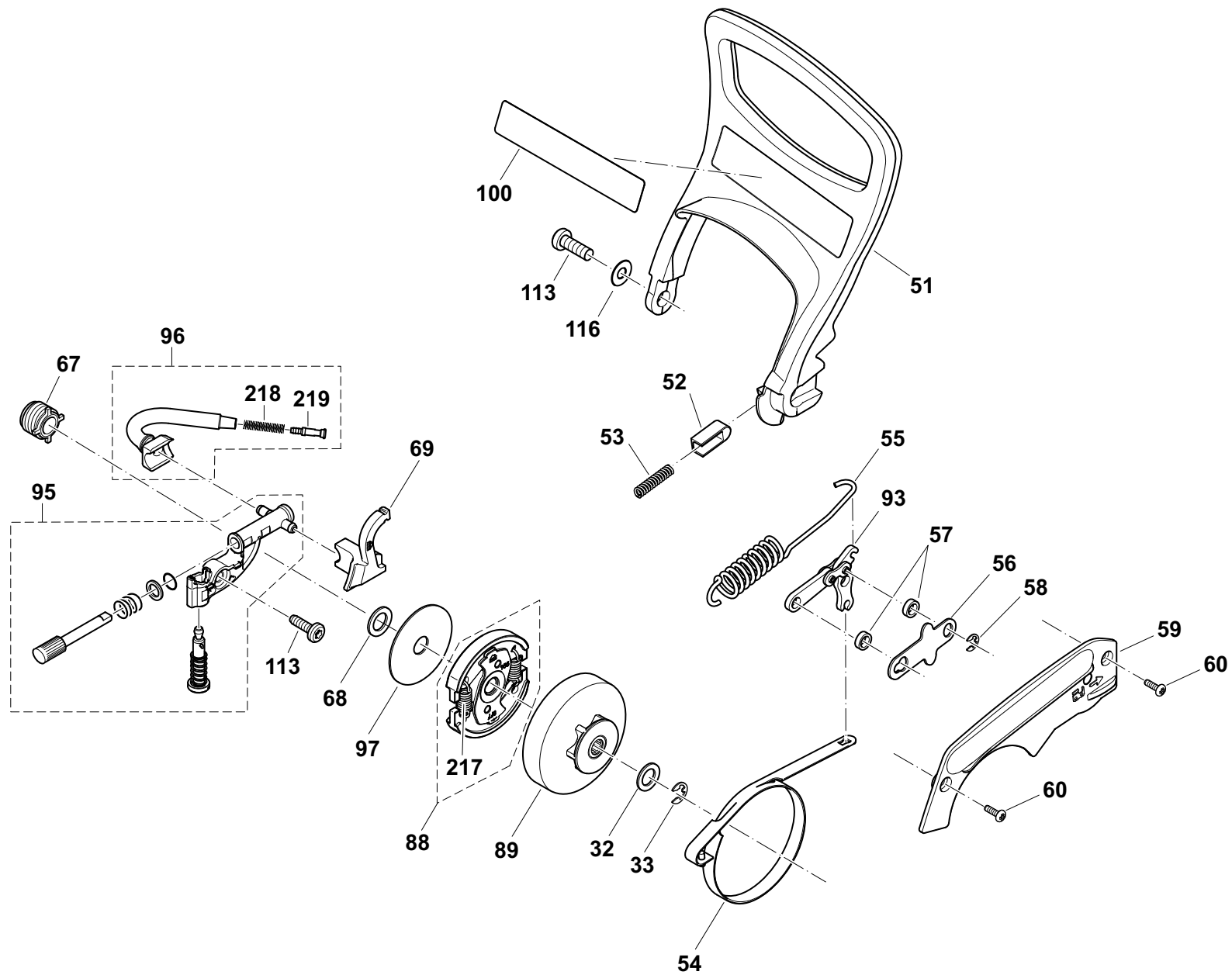

PS-32 C, PS-32 C TLC,
PS-32, PS-32 TLC

5

Ölpumpe, Kupplung, Kettenbremse
Oil pump, clutch, chain brake
Pompe à huile, embrayage, frein de chaîne
Bomba de aceite, engrague, freno de cadena

DOLMAR
A member of the **Takita** Group

Seite / Page	Pos.	PS-32 C	PS-32 C TLC	PS-32	PS-32 TLC	Teil-Nr. Part No. No. de pièce No. de pieza	Hinweise Notes Renseign. Nota	Bezeichnung	Spezifikation Specification	Description	Désignation	Denominación
5	32	1	1	1	1	900 006 065		PASSSCHEIBE	ø8/14x1	WASHER	RONDELLE	ARANDELA
5	33	1	1	1	1	927 306 000		SICHERUNGSSCHEIBE		SAFETY WASHER	RONDELLE SÉCURITÉ	ARANDELA SEGURIDAD
5	51	1	1	1	1	165 213 050		HANDSCHUTZ		HAND GUARD	PROTÈGE-MAIN	PROTECTOR DE MANO
5	52	1	1	1	1	181 213 070		KULISSE FÜR HANDSCHUTZ		HANDGUARD GUIDE, CPL.	COULISSE P. PROTÈGE-MAINS CPL.	CULISA P. PROTECCIÓN DE MANOS
5	53	1	1	1	1	181 213 060		DRUCKFEDER FÜR KULISSE		COMPRESSION SPRING	RESSORT DE PRESSION	RESORTE DE PRESION
5	54	1	1	1	1	165 213 010		BREMSBAND		BRAKE BAND	RESSORT DE FREIN	CINTA DE FRENO
5	55	1	1	1	1	165 213 120		ZUGFEDER		TENSION SPRING	RESSORT	MUELLE
5	56	1	1	1	1	165 213 130		ABSTANDSBLECH		SPACER SHEET METAL	TÔLE DE DISTANCE	CHAPA DE SEPARADOR
5	57	2	2	2	2	165 213 140		BUCHSE		BUSH	DOUILLE	CASQUILLO
5	58	1	1	1	1	927 304 000		SICHERUNGSSCHEIBE		SAFETY WASHER	RONDELLE SÉCURITÉ	ARANDELA SEGURIDAD
5	59	1	1	1	1	165 213 190		ABDECKUNG KETTENBREMSE		CHAIN BRAKE COVER	COUVERCLE	CUBIERTA
5	60	4	4	4	4	165 888 120		SCHRAUBE	3X10 KS K	TAPPING SCREW	VIS	TORNILLO
5	67	1	1	1	1	170 245 130		SCHNECKE		PUMP DRIVE	LE COMMANDE DE POMPE	PROPULSOR DE LA BOMBA
5	68	1	1	1	1	036 224 041		DISTANZSCHEIBE	ø10/16x2,2	WASHER	RONDELLE	ARANDELA
5	69	1	1	1	1	165 245 120		ÖLDRUCKLEITUNG		OIL PRESSURE LINE	CONDUITE HUILE	TUBO ACEITE
5	88	1	1	1	1	165 180 200		KUPPLUNG KPL.		CLUTCH ASSY.	EMBRAYAGE CPL.	EMBRAGUE CPL.
5	89	1	1	1	1	170 223 111		KUPPLUNGSTROMMEL KPL.	3/8"	CLUTCH DRUM CPL.	TAMBOUR CPL.	TAMBOR CPL.
5	93	1	1	1	1	181 213 100		BREMSMECHANIK KPL.		BRAKING MECHANISM	MECANISME DE FREINAGE	MECANISMO DE FRENO
5	95	1	1	1	1	179 245 201		ÖLPUMPE KPL.		OIL PUMP CPL.	POMPE À HUILE CPL.	BOMBA DE ACEITE CPL.
5	96	1	1	1	1	181 245 100		ÖLSAUGLEITUNG KPL.		SUCTION LINE	CONDUITE HUILE CPL.	TUBO ACEITE CPL.
5	97	1	1	1	1	165 182 060		FÜHRUNGSSCHEIBE	10	FLAT WASHER	RONDELLE	ARANDELA
5	100	1	1	1	1	980 114 237		SCHILD HANDSCHUTZ		LABEL	PLAQUE	CALCOMANIA
5	100	1	1	1	1	980 115 808		SICHERHEITSAUFKLEBER	US WARNING SPARKS	CAUTION LABEL	PLAQUE	CALCOMANIA
5	113	2	2	2	2	165 888 110		SCHRAUBE INNEN6RD	4,7X16 ZK K	H.L.TAPPING SCREW	VIS	TORNILLO
5	116	1	1	1	1	925 305 000		SCHEIBE	ø5/12x0,5	WASHER	RONDELLE	ARANDELA
5	217	2	2	2	2	165 184 020		ZUGFEDER	5	TENSION SPRING	RESSORT DE TRACTION	MUELLE DE TRACCIÓN
5	218	1	1	1	1	021 245 060		DRUCKFEDER		SPRING	RESSORT	MUELLE
5	219	1	1	1	1	001 245 020		NIPPEL		HOSE STEM	TETON DE TUYAU	BOQUILLA DE TUBO

PS-32 C, PS-32 C TLC,
PS-32, PS-32 TLC

6

Motorträger, Kettenradchutz, Kettenspanner
Motor housing, sprocket guard, chain tensioner
Carter du moteur, protège-pignon, tendeur de chaîne
Cárter de motor, protector de piñon, tensor de la cadena

DOLMAR
A member of the *Trakita* Group

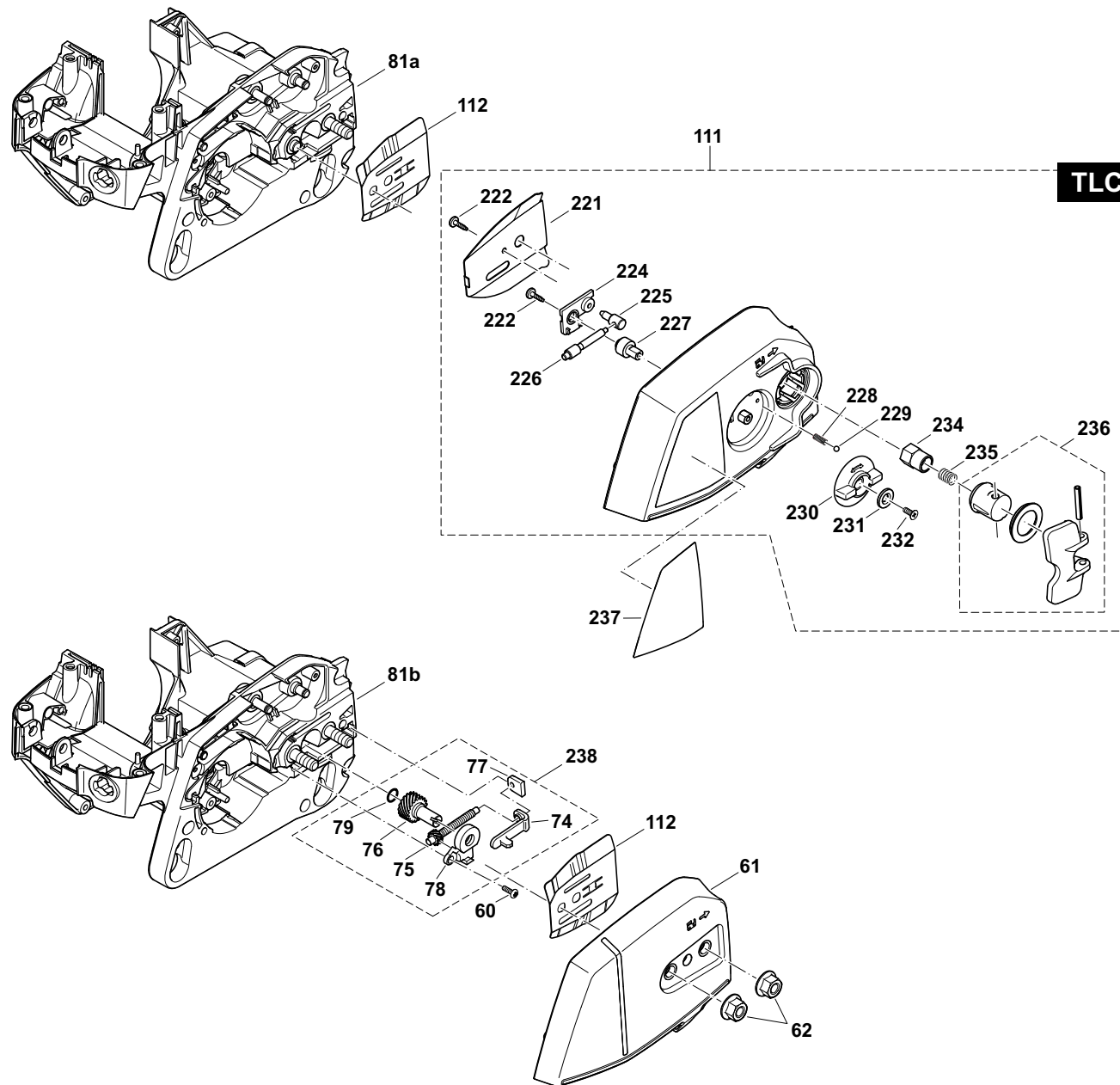

PS-32 C, PS-32 C TLC,
PS-32, PS-32 TLC

6

Motorträger, Kettenradschutz, Kettenspanner
Motor housing, sprocket guard, chain tensioner
Carter du moteur, protège-pignon, tendeur de chaîne
Cárter de motor, protector de piñon, tensor de la cadena

DOLMAR
A member of the **Takita** Group

Seite / Page	Pos.	PS-32 C	PS-32 C TLC	PS-32	PS-32 TLC	Teil-Nr. Part No. No. de pièce No. de pieza	Hinweise Notes Renseign. Nota	Bezeichnung	Spezifikation Specification	Description	Désignation	Denominación
6	60	4		4		165 888 120		SCHRAUBE	3X10 KS K	TAPPING SCREW	VIS	TORNILLO
6	61	1		1		165 213 200		KETTENRADSCHUTZ KPL. ROT	RED	SPROCKET GUARD CPL.	PROTÈGE-PIGNON CPL.	PROTECTOR DE PIÑON CPL.
6	62	2		2		923 208 004		6KT-MUTTER	M8	HAXAGONAL NUT	ECROU HEXAGONAL	TUERCA HEXAGONAL
6	74	1		1		165 213 240		SPANNSCHLITTEN		TENSION SLIDE	COULISSEAU DE SERRAGE	CARRO DE TENSADO
6	75	1		1		181 213 230		KETTENSPANNSCHRAUBE	PROFI	TENSIONING SCREW	VIS DE TENSION	TORNILLO DE TENSION
6	76	1		1		181 213 250		EINSTELLSCHRAUBE	PROFI	ADJUSTING SCREW	VIS DE REGLAGE	TORNILLO DE AJUSTE
6	77	1		1		181 213 260		SPANNSCHRAUBENLAGER		TENSIONING SCREW BEARING	PALIER DE LA VIS DE TENSION	SOPORTE DEL TORNILLO TENSOR
6	78	1		1		181 213 270		GETRIEBEABDECKUNG	PROFI	TRANSMISSION COVER	REVÊTEMENT D' ENGRENAJES	CUBIERTA DE ENGRANAJES
6	79	1		1		963 207 020		O-RING	7X2	PACKING RING	BAGUE-JOINT	ANILLO DE GUARNICION
6	81a		1		1	165 110 200		MOTORTRÄGER KPL. ROT	RED, TLC	ENGINE HOUSING COMPLETE	CARTER DU MOTEUR CPL.	CARTER DE MOTOR CPL.
6	81b	1		1		165 110 100		MOTORTRÄGER KPL. ROT	RED	ENGINE HOUSING COMPLETE	CARTER DU MOTEUR CPL.	CARTER DE MOTOR CPL.
6	111		1		1	165 213 160		KETTENRADSCHUTZ KPL. ROT	RED, TLC	SPROCKET GUARD COMPLETE	PROTEGE-PIGNON CPL.	PROTECTOR DE PINON CPL.
6	112	1	1	1	1	195 213 120		KETTENFÜHRUNGSBLECH		GUIDE PLATE	TÔLE DE GUIDAGE	CHAPA DE GUÍA
6	221		1		1	165 213 310		KETTENFÜHRUNGSBLECH		GUIDE PLATE	TÔLE DE GUIDAGE	CHAPA DE GUÍA
6	222		2		2	320 266 007		GEWINDESCHNEIDSCHRAUBE	3,0X10	TAPPING SCREW BIND	VIS TARAUDEUSE	TORNILLO DE ROSCA CORTANTE
6	224		1		1	170 213 670		KETTENSPANNABDECKUNG		COVER	COUVERCLE	CUBIERTA
6	225		1		1	170 213 660		SPANNMUTTER		TENSIONING NUT	ECROU DE TENSION	TUERCA DE TENSION
6	226		1		1	170 213 650		SPANNSCHRAUBE		TENSIONING SCREW	VIS DE TENSION	TORNILLO DE TENSION
6	227		1		1	170 213 710		ANTRIEBSRAD	TLC	HELICAL GEAR	ROUE HÉLICOÏDALE	RUEDA HELICOIDAL
6	228		1		1	170 213 690		FEDER F.STAHLKUGEL	4	SPRING	RESSORT	MUELLE
6	229		1		1	170 213 770		STAHLKUGEL	4	LOCKING BALL	BILLE D ARRÊT	BOLA DE TOPE
6	230		1		1	226 213 340		SPANNRAD	40	TENSIONING WHEEL	ROUE DE SERRAGE	RUEDA TENSORA
6	231		1		1	924 204 020		SCHEIBE FÜR SPANNRAD	4X12X0,5	WASHER	DISQUE	ARANDELA
6	232		1		1	226 213 380		SCHRAUBE	(P+) M4X8	SCREW	VIS	TORNILLO
6	234		1		1	165 213 720		KLEMM-MUTTER	M8	HEX. NUT	ECROU DE CALAGE	TUERCA DE APRIETE
6	235		1		1	170 213 730		FEDER FÜR KLEMMUTTER	8	SPRING	RESSORT	MUELLE
6	236		1		1	170 213 150		FLÜGELGRIFF KPL.		WING GRIP CPL.	POIGNEE À AILETTE CPL.	MANGO MARIPOSA CPL.
6	237		1		1	165 115 150		AUFKLEBER KETTENRADSCHUTZ	TLC	LABEL	PLAQUE	CALCOMANIA
6	238	1		1		195 213 300		KETTENSPANNER KPL.	PROFI	CHAIN TENSIONER CPL.	TENDEUR DE CHÂÎNE CPL.	SENSOR DE LA CADENA CPL.

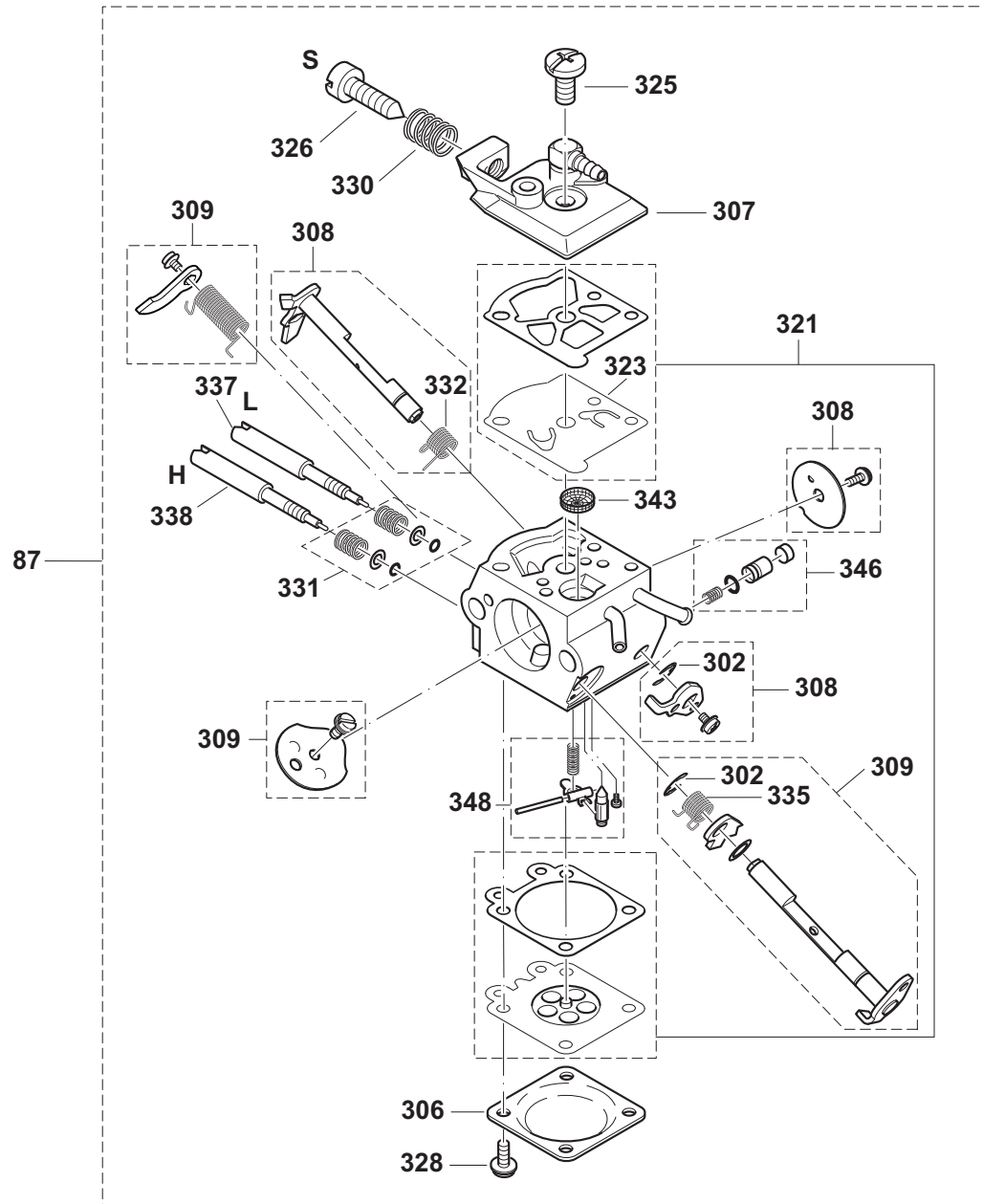

PS-32 C, PS-32 C TLC,
PS-32, PS-32 TLC

7

Vergaser
Carburetor
Carburateur
Carburador

DOLMAR
A member of the **Takita** Group

Seite / Page	Pos.	PS-32 C	PS-32 C TLC	PS-32	PS-32 TLC	Teil-Nr. Part No. No. de pièce No. de pieza	Hinweise Notes Renseign. Nota	Bezeichnung	Spezifikation Specification	Description	Désignation	Denominación
7	87	1	1	1	1	165 151 100		VERGASER	WTE13	CARBURETOR	CARBURATEUR	CARBURADOR
7	302	1	1	1	1	119 151 350		WELLENSICHERUNG		SHAFT CLIP	TÔLE DE SÉCURITÉ	PIEZA SEGURIDAD ARBÓL
7	306	1	1	1	1	021 151 120		MEMBRANDECKEL		DIAPHRAGM COVER	COUVERCLE DE MEMBRANE	TAPA DE MEMBRANA
7	307	1	1	1	1	165 151 350		PUMPENDECKEL KPL.		PUMP COVER CPL.	COUVERCLE DE POMPE CPL.	TAPA DE BOMBA CPL.
7	308	1	1	1	1	165 151 200		REP.-SATZ DROSSELWELLE		KIT THROTTLE SHAFT	JEU AXE CLAPET D'ÉTRANG.	JUEGO EJE VÁLVULA REG.
7	309	1	1	1	1	165 151 210		REP.-SATZ CHOKEWELLE		KIT CHOKE SHAFT	JEU AXE CLAPET D'AIR	JUEGO EJE VÁLVULA AIRE
7	321	1	1	1	1	957 151 220		SATZ MEMBRANEN UND DICHTUNGEN		SET DIAPHRAGM / GASKETS	JEU DE MEMBRANES / JOINTS	JUEGO MEMBRANAS / JUNTAS
7	323	1	1	1	1	021 151 150		PUMPENMEMBRAN GUMMI		PUMP DIAPHRAGM, RUBBER	MEMBRANE DE POMPE, CAOUTCH.	MEMBRANA DE LA BOMBA, CAUCHO
7	325	1	1	1	1	118 151 190		SCHRAUBE		SCREW	VIS	TORNILLO
7	326	1	1	1	1	378 151 210		LEERLAUFANSLAGSCHRAUBE	S	IDLE SPEED SCREW	VIS DE BUTÉE DE RALENTI	TORNILLO DE TOPE
7	328	4	4	4	4	378 151 220		SCHRAUBE		SCREW	VIS	TORNILLO
7	330	1	1	1	1	021 151 230		DRUCKFEDER	S	COMPRESSION SPRING	RESSORT DE PRESSION	RESORTE DE PRESIÓN
7	331	1	1	1	1	957 151 240		SATZ FEDERN UND SCHEIBEN		SET SPRINGS / WASHERS	SET RESSORTS / RONDELLES	JUEGO RESORTES / ARANDELAS
7	332	1	1	1	1	001 151 310		DREHFEDER		SPRING	RESSORT	RESORTE
7	335	1	1	1	1	195 151 490		DREHFEDER		SPRING	RESSORT	RESORTE
7	337	1	1	1	1	195 151 520		LEERLAUF-STELLSCHRAUBE	L	IDLE ADJUSTMENT SCREW	VIS DE RÉGL. DE RALENTI	TORNILLO REGULADOR
7	338	1	1	1	1	195 151 530		VOLLGAS-STELLSCHRAUBE	H	MAIN ADJUSTMENT SCREW	VIS DE RÉGL. PLEIN GAZ	TORNILLO REGULADOR
7	343	1	1	1	1	021 151 180		SIEB		SCREEN	TAMIS	TAMIZ
7	346	1	1	1	1	165 151 070		BESCHLEUNIGUNGSPUMPE KPL.		ACCELERATOR	POMPE DE REPRISE	BOMBA DE ACELERACIÓN
7	348	1	1	1	1	165 151 230		SATZ STEUERTEILE		SET OF CONTROL PARTS	JEU DE PIÈCES DE COMMANDE	JUEGO PIEZAS DE MANDO

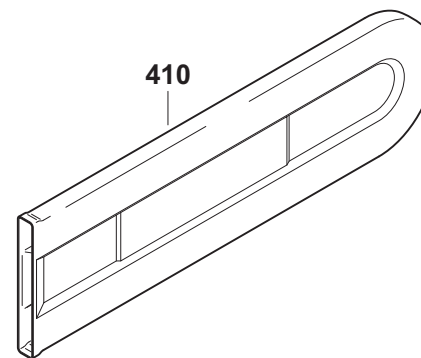
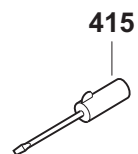
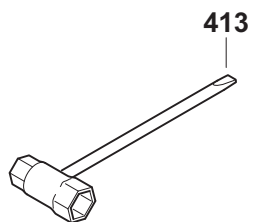
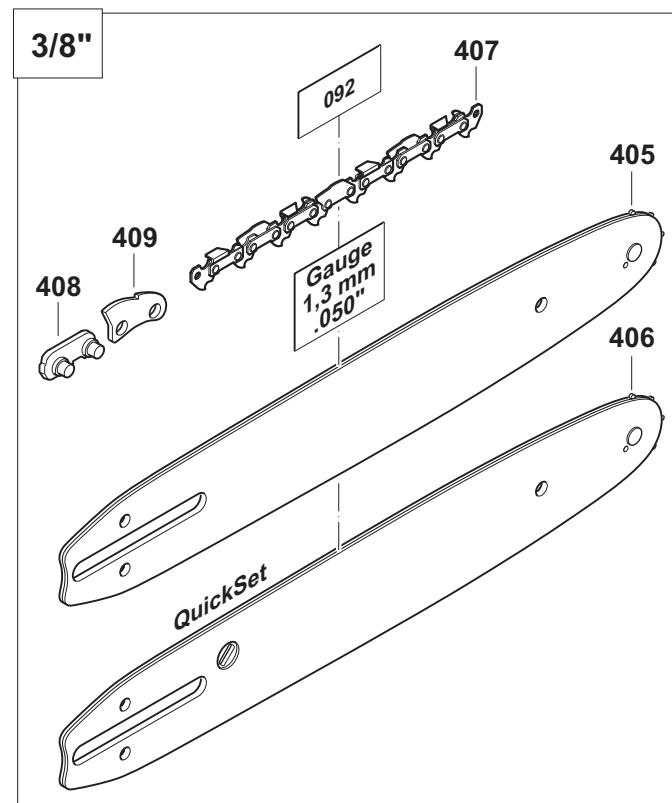
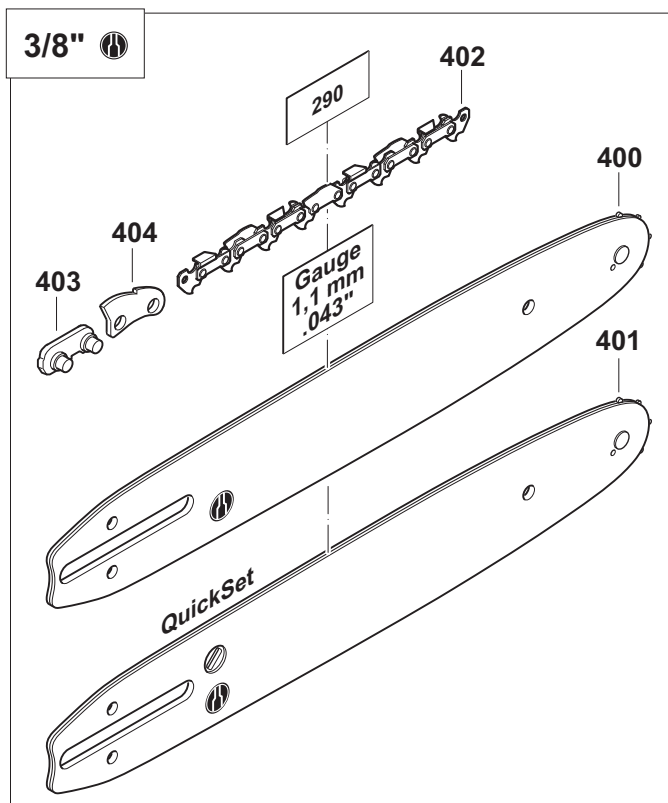

PS-32 C, PS-32 C TLC,
PS-32, PS-32 TLC

8

Werkzeuge, Zubehör
Tools, accessories
Outils, accessoires
Herramientas, accesorios

DOLMAR
A member of the **Takita** Group

Seite / Page	Pos.	PS-32 C	PS-32 C TLC	PS-32	PS-32 TLC	Teil-Nr. Part No. No. de pièce No. de pieza	Hinweise Notes Renseign. Nota	Bezeichnung	Spezifikation Specification	Description	Désignation	Denominación
8	400	1	1	1	1	412 030 611		STERNSCHIENE	3/8" .043" 30cm-12"	SPROCKET NOSE BAR	GUIDE À ÉTOILE	GUÍA CON ESTRELLA
8	400	1	1	1	1	412 035 611		STERNSCHIENE	3/8" .043" 35cm-14"	SPROCKET NOSE BAR	GUIDE À ÉTOILE	GUÍA CON ESTRELLA
8	401	1		1		412 030 211		STERNSCHIENE QUICKSET	3/8" .043" 30cm-12"	SPROCKET NOSE BAR	GUIDE À ÉTOILE	GUÍA CON ESTRELLA
8	401	1		1		412 035 211		STERNSCHIENE QUICKSET	3/8" .043" 35cm-14"	SPROCKET NOSE BAR	GUIDE À ÉTOILE	GUÍA CON ESTRELLA
8	402	1	1	1	1	511 290 746		SÄGEKETTE	3/8" .043" 30cm-12"	SAW CHAIN	CHAÎNE	CADENA
8	402	1	1	1	1	511 290 752		SÄGEKETTE	3/8" .043" 35cm-14"	SAW CHAIN	CHAÎNE	CADENA
8	403	1	1	1	1	510 090 010		AUSSENLASCHE MIT NIET	.043"	TIE STRAP WITH RIVETS	ECLISSE EXTER. A. RIVETS	TIRA EXTER. CON REMACHE
8	404	1	1	1	1	510 090 030		SICHERHEITSLASCHE	.043"	SAFETY TIE STRAP	ECLISSE DE SÉCURITÉ	TIRA SEGURIDAD
8	405	1	1	1	1	412 030 661		STERNSCHIENE	3/8" .050" 30cm-12"	SPROCKET NOSE BAR	GUIDE À ÉTOILE	GUÍA CON ESTRELLA
8	405	1	1	1	1	412 035 661		STERNSCHIENE	3/8" .050" 35cm-14"	SPROCKET NOSE BAR	GUIDE À ÉTOILE	GUÍA CON ESTRELLA
8	405	1	1	1	1	412 040 661		STERNSCHIENE	3/8" .050" 40cm-16"	SPROCKET NOSE BAR	GUIDE À ÉTOILE	GUÍA CON ESTRELLA
8	406	1		1		412 030 061		STERNSCHIENE QUICKSET	3/8" .050" 30cm-12"	SPROCKET NOSE BAR	GUIDE À ÉTOILE	GUÍA CON ESTRELLA
8	406	1		1		412 035 061		STERNSCHIENE QUICKSET	3/8" .050" 35cm-14"	SPROCKET NOSE BAR	GUIDE À ÉTOILE	GUÍA CON ESTRELLA
8	406	1		1		412 040 061		STERNSCHIENE QUICKSET	3/8" .050" 40cm-16"	SPROCKET NOSE BAR	GUIDE À ÉTOILE	GUÍA CON ESTRELLA
8	407	1	1	1	1	511 492 756		SÄGEKETTE	3/8" .050" 40cm-16"	SAW CHAIN	CHAÎNE	CADENA
8	407	1	1	1	1	511 492 752		SÄGEKETTE	3/8" .050" 35cm-14"	SAW CHAIN	CHAÎNE	CADENA
8	407	1	1	1	1	528 092 746		SÄGEKETTE	3/8" .050" 30cm-12"	SAW CHAIN	CHAÎNE	CADENA
8	408	1	1	1	1	558 092 010		AUSSENLASCHE MIT NIET	3/8" .050"	TIE STRAP WITH RIVETS	ECLISSE EXTER. A. RIVETS	TIRA EXTER. CON REMACHE
8	409	1	1	1	1	558 092 000		SICHERHEITSLASCHE	3/8" .050"	SAFETY TIE STRAP	ECLISSE DE SÉCURITÉ	TIRA SEGURIDAD
8	410	1	1	1	1	952 010 130		KETTENSCHUTZ	30 cm	CHAIN PROTECTION	PROTECTION CHAÎNE	PROTECTOR DE CADENA
8	410	1	1	1	1	952 010 140		KETTENSCHUTZ	43 cm	CHAIN PROTECTION	PROTECTION CHAÎNE	PROTECTOR DE CADENA
8	413	1	1	1	1	941 713 160		KOMBISCHLÜSSEL	SW 13/16	UNIVERSAL WRENCH	CLÉ COMBINÉE	LLAVE DE BUJIA
8	415	1	1	1	1	944 340 001		SCHRAUBENDREHER		SCREWDRIVER	TOURNEVIS	DESTORNILLADOR

PS-32 C, PS-32 C TLC,
PS-32, PS-32 TLC

DOLMAR



A member of the **Takita** Group

	Zeichenerklärung	Key to symbols	Légende	Explicación de símbolos
=> 1999999 2000000 => 2003.04 => TI 2003/07 Acc. = { m Corr.	Produktion bis Serien-Nr. Neues Teil ab Serien-Nr. Neues Teil ab Jahr / Monat Siehe Technische Information Jahr / Nr. Zubehör (nicht im Lieferumfang) Keine Serienausführung, jedoch verwendbar Beinhaltet Positions-Nr. Meterware Druckfehlerberichtigung	Production to serial number New part from serial number New part from Year / Month See Technical Information Year / No. Accessories (not included in the delivery inventory) No standard execution, may be used Contains item number Sold by the meter Error correction	Production jusqu'à n° de série Nouveau pièce à partir du n° de série Nouveau pièce à partir de année / mois Voir information technique année / n° Accessoires (non compris dans la livraison) Aucune exécut. en série, cependant utilisable contient n° de numéro Au mètre Rectification d'erreurs	Producción hasta N° de serie Pieza nueva a partir de N° de serie Pieza nueva a partir de año / mes Véase inform. técnico año / N° Accesorios (no incluido en la extensión del suministro) No es de serie, pero sirve Contiene pos N° Por metro Fe de erratas
	Änderungen vorbehalten	Specifications subject to change without notice	Changements sans préavis	Mejoras constructivas sin previo aviso